

LISTA DE PEÇAS

Nº	Descrição de Peças	QTD.
01	Base do Nicho	02
02	Tampo do Nicho	01
03	Laterais do nicho	02
04	Divisão do Nicho	01
05	Lateral Esquerda Maior	01
06	Lateral Direita Maior	01
07	Lateral Esquerda Menor	01
08	Lateral Direita Menor	01
09	Base Direito e Esquerdo	02
10	Tampo Gaveta Esquerdo	01
11	Tampo Gaveta Direito	01
12	Tampo Esquerdo	01
13	Tampo Direito	01
14	Frente de Gaveta	02
15	Lateral de Gaveta	04
16	Contra Fundo de Gaveta	02
17	Fundo de Gaveta (61,4 x 35,8 x 3)	02
18	Fundo (66,5 x 31,0 x 3)	02

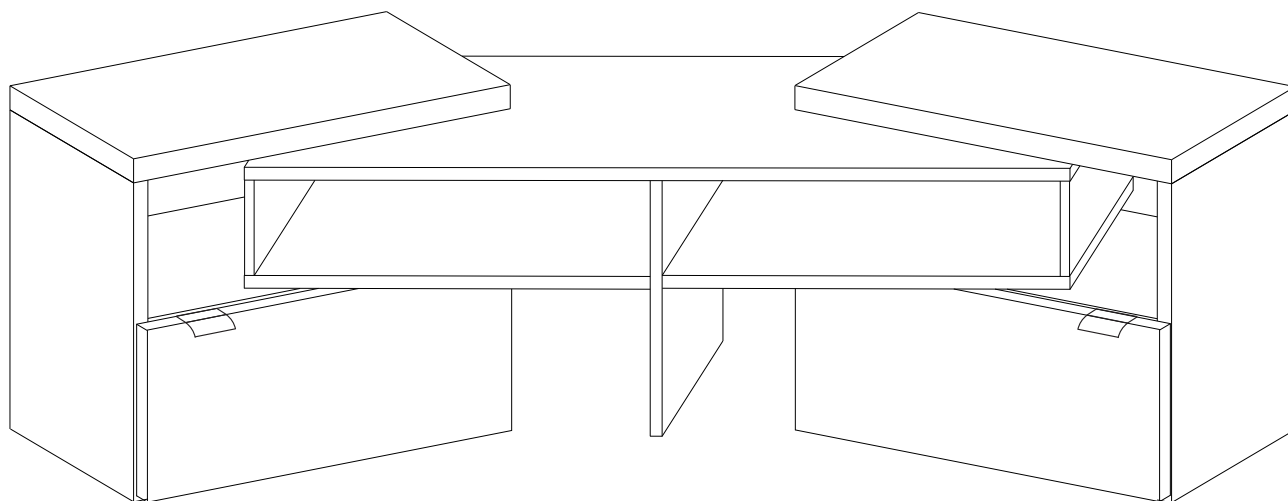











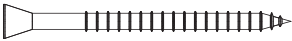



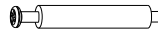

PARA A LIMPEZA E CONSERVAÇÃO DO SEU MÓVEL

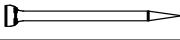

Não use produtos abrasivos como Álcool, Solventes, Acetona e etc...

Use somente um pano macio e seco.

Rack Extensivo

	DESCRIÇÃO	QTD
A	 Parafuso 3,5 x 40	04
B	 Parafuso 3,5 x 12	36
C	 Parafuso 4,0 x 25	08
D	 Pino Girofix Simples	15
E	 Cavilha 06 x 30	38
F	 Tampa Girofix	09
G	 Corrediça Telescópica	02
H	 Pino girofix Duplo	02
I	 Castanha girofix	19
J	 Sachet de cola	01
K	 Sapata deslizante	10
L	 Cavilha 06 x 55	02
M	 Prego 08 x 08	74
N	 Giz de Correção	02
O	 Etiqueta	01
P	 Porca cilíndrica 9 x 12	04
Q	 Puxador	02
R	 Cantoneira de Gaveta	08

DESEMBALANDO

Identifique todas as peças e deixe-as de pé, nunca coloque umas sobre as outras. Utilize a própria embalagem como tapete para a montagem do produto.

Passo 01



Separe as duas partes das corredeiras telescópicas, seguindo os seguintes passos:

- 1 - Abra toda a corredeira;
- 2 - Empurre a trava de segurança para cima;
- 3 - Mantenha a trava levantada e puxe a ponta da corredeira para frente.

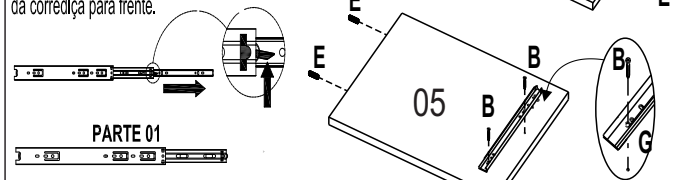

PARTE 01

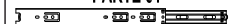

A PRIMEIRA PARTE FIXA NAS LATERAIS

PARTE 02

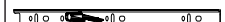

A SEGUNDA PARTE FIXA NA LATERAL DE GAVETA

Passo 02

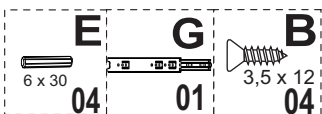

Separe as duas partes das corredeiras telescópicas, seguindo os seguintes passos:

- 1 - Abra toda a corredeira;
- 2 - Empurre a trava de segurança para cima;
- 3 - Mantenha a trava levantada e puxe a ponta da corredeira para frente.

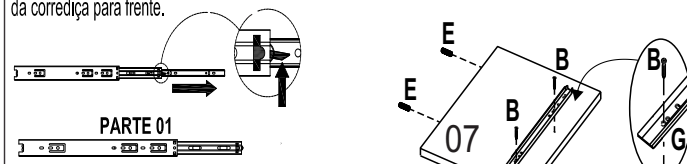

PARTE 01

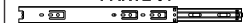

A PRIMEIRA PARTE FIXA NAS LATERAIS

PARTE 02

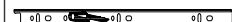

A SEGUNDA PARTE FIXA NA LATERAL DE GAVETA

Passo 03

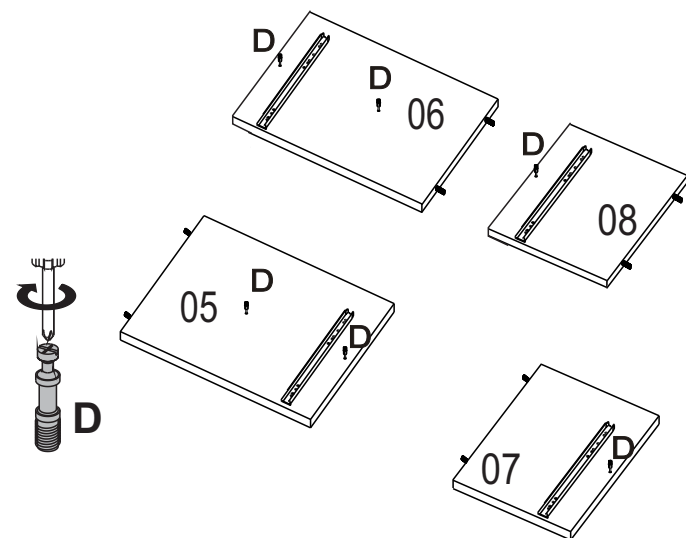
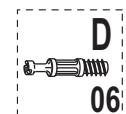

Passo 04

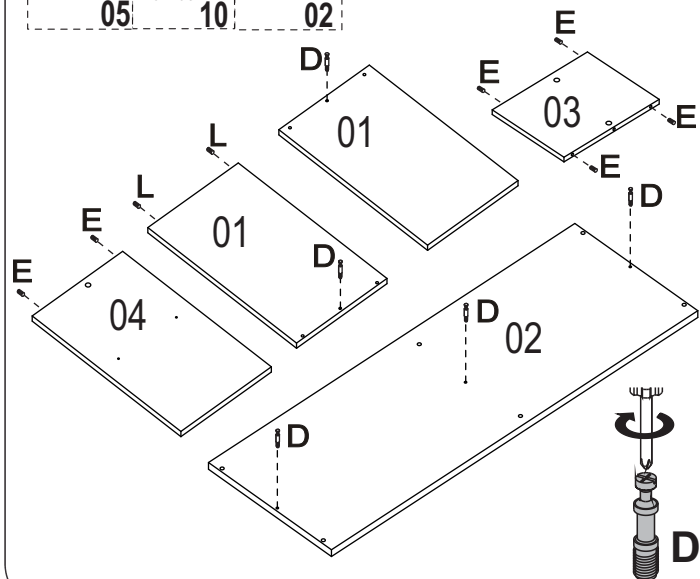
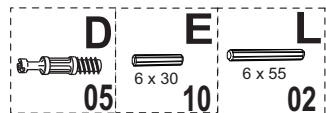

Passo 05

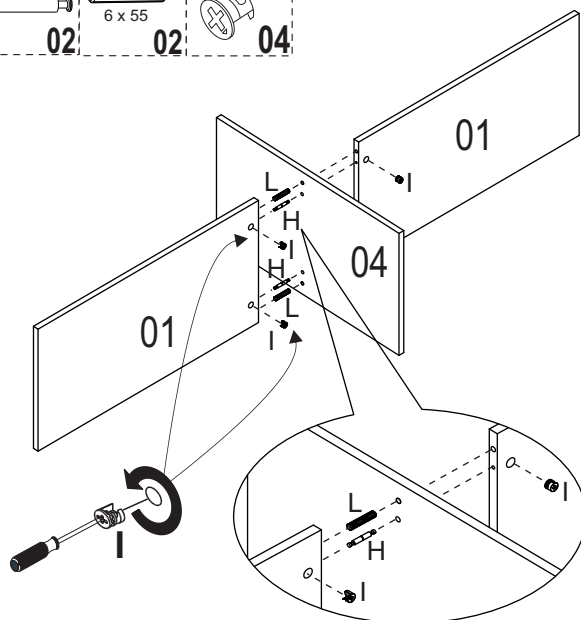
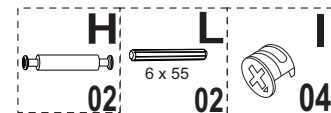

Passo 06

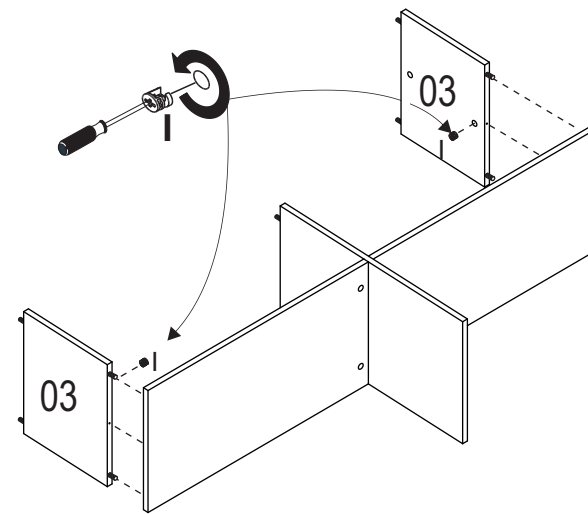

Passo 07

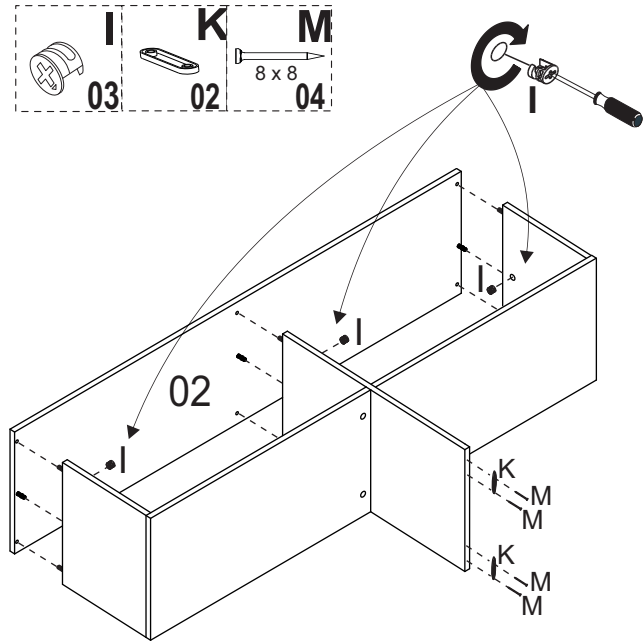

Passo 08

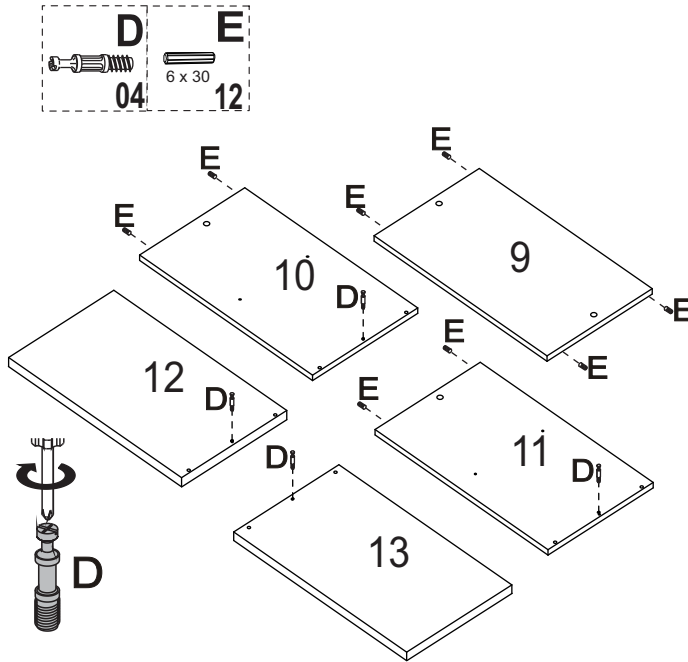

Passo 09

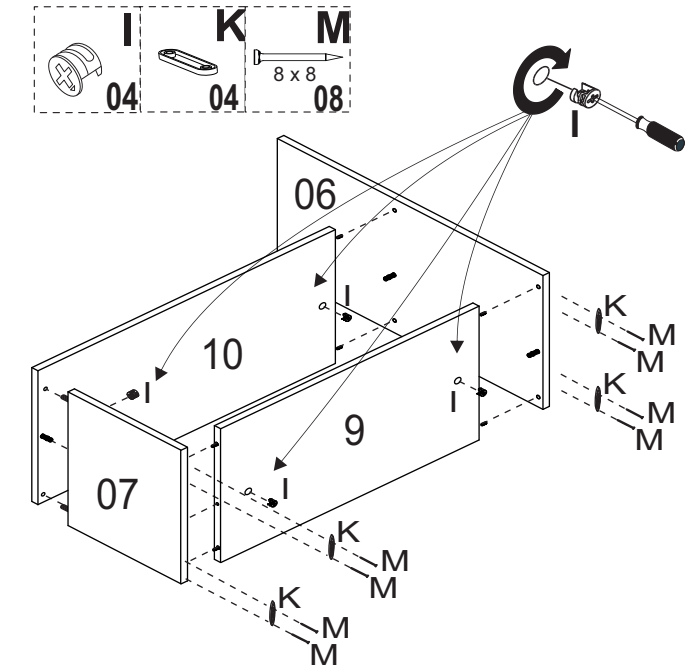

Passo 10

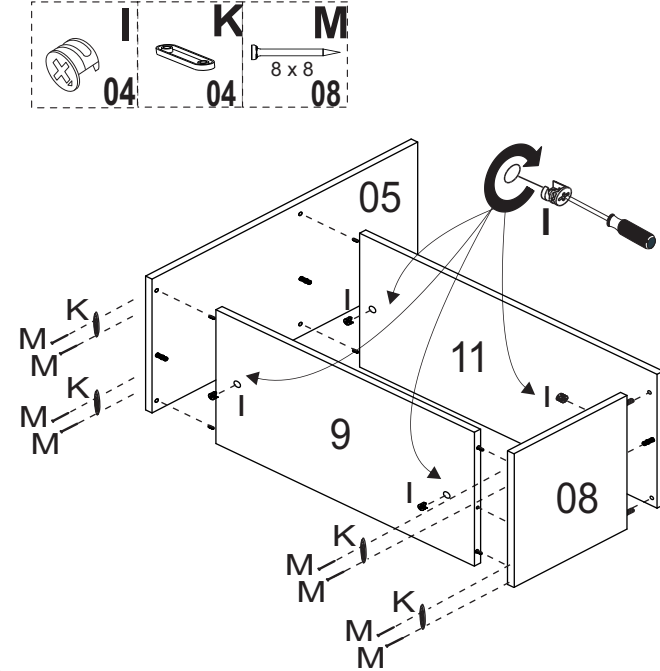

Passo 11

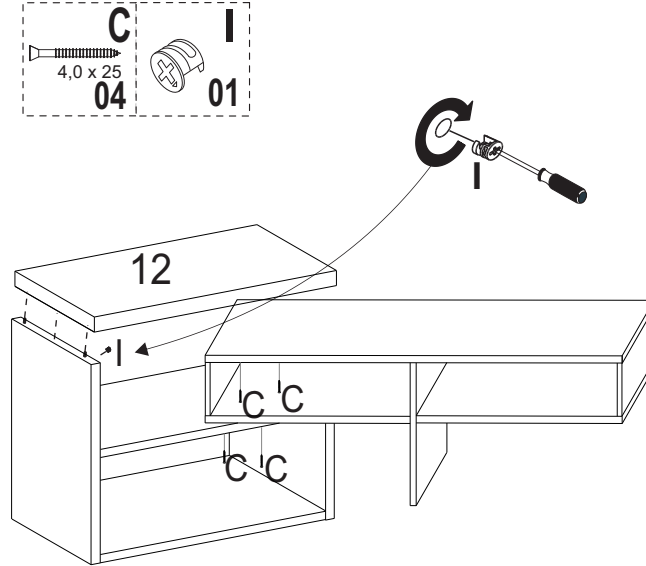

Passo 12

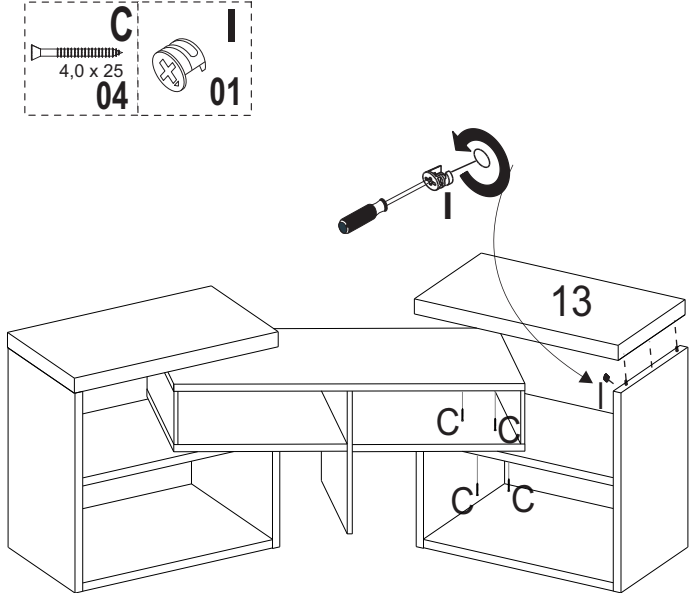

Passo 13

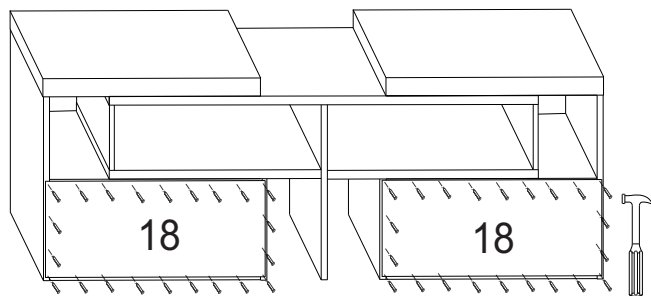
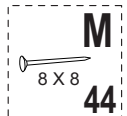

Passo 14

Sem Gaveta

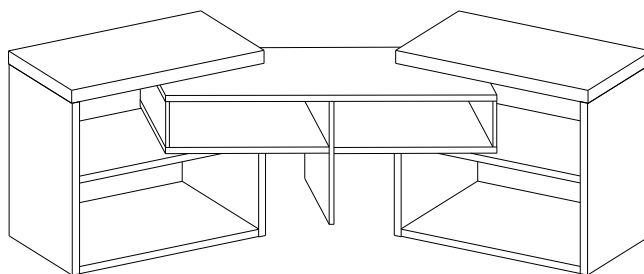

OU

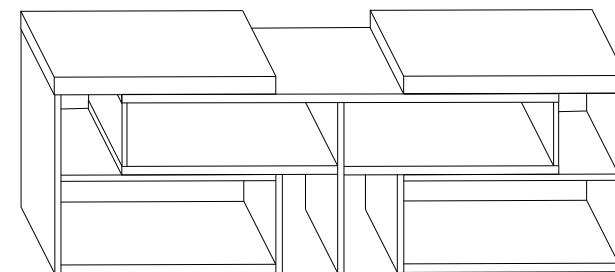

Passo 15

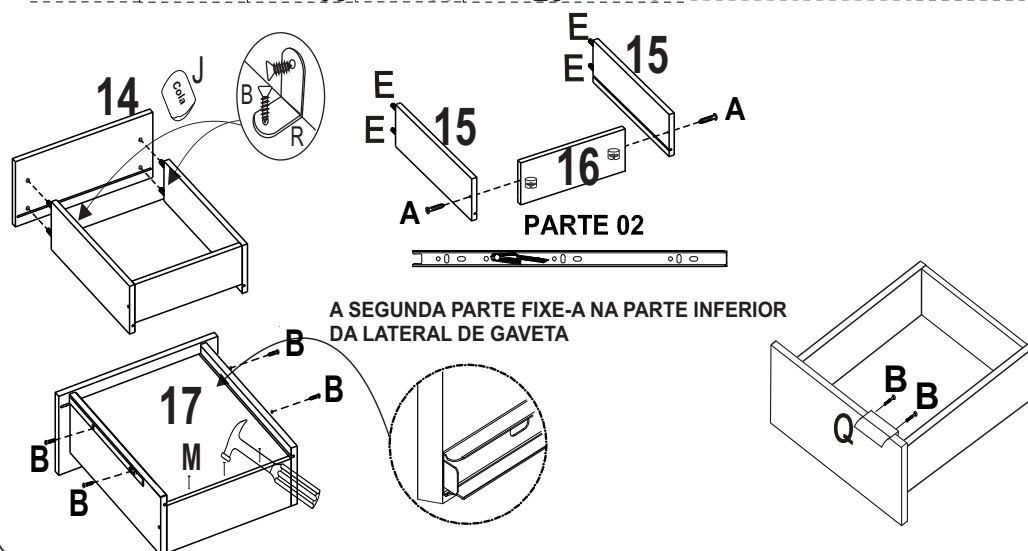
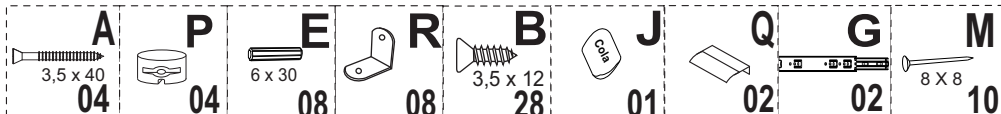

Passo 16

Com Gaveta

