

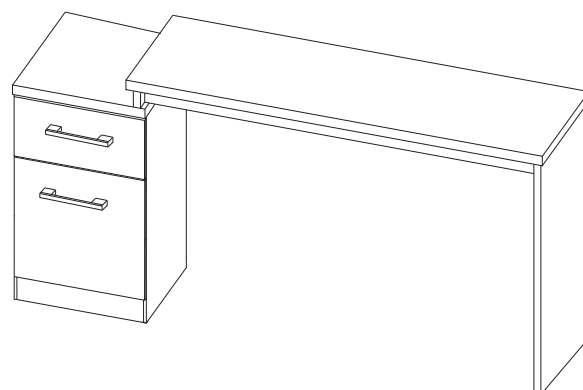

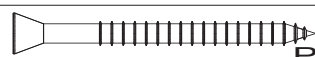







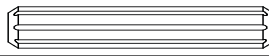

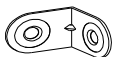

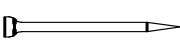

### LISTA DE PEÇAS

Nº	Descrição de Peças	QTD.
01	Lateral Esquerda	01
02	Costa da Mesa	01
03	Lateral Direita	01
04	Lateral Direita Gaveteiro	01
05	Lateral Esquerda Gaveteiro	01
06	Rodapé Frontal e Traseiro	02
07	Base	01
08	Tampo do Gaveteiro	01
09	Tampo	03
10	Frente de Gaveta	06
11	Porta	03
12	Lateral de Gaveta	03
13	Contra Fundo de Gaveta	01
14	Fundo de Gaveta ( 35,3 x 35,8 x 3 )	03
15	Fundo Gaveteiro ( 60,0 x 44,5 x 3 )	01



## Escrivaninha Belgrado

DESCRIÇÃO		QTD
A	 Parafuso 3,5 x 40	14
B	 Parafuso 4,0 x 25	04
C	 Parafuso 3,5 x 12	24
D	 Cavilha 06 x 30	12
E	 34x7mm Parafuso minifix	06
F	 15x12mm Tambor minifix	06
G	 Cantoneira	04
H	 Corrediça Telescópica	01
I	 Sachet de cola	01
J	 Puxador	02
K	 Etiqueta	01
L	 Sapata Deslizante	06
M	 Prego 08 x 08	32
N	 Adesivo tapa furo	14
O	 Giz de Correção	01
P	 Porca cilíndrica 9 x 12	16
Q	 Dobradiça	02
R	 Calço de Dobradiça	02

### PARA A LIMPEZA E CONSERVAÇÃO DO SEU MÓVEL

- Não use produtos abrasivos como Álcool, Solventes, Acetona e etc...
- Use somente um pano macio e seco.

### DESEMBALANDO

Identifique todas as peças e deixe-as de pé, nunca coloque umas sobre as outras. Utilize a própria embalagem como tapete para a montagem do produto.

## Passo 01

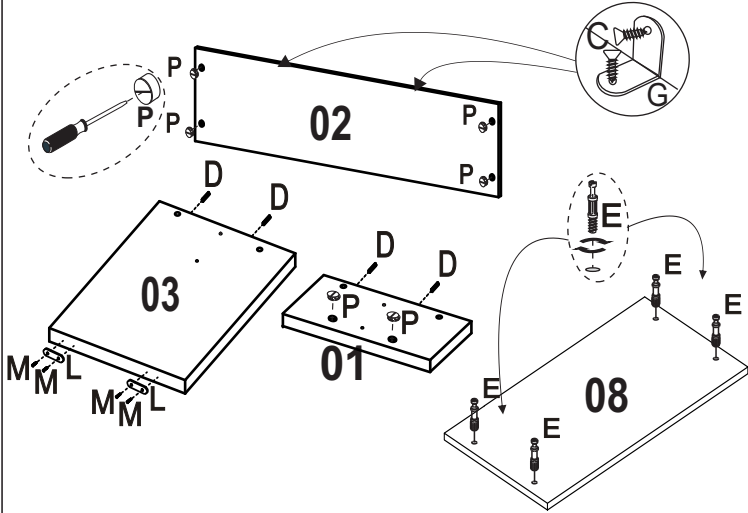
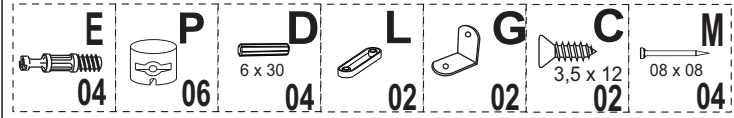

## Passo 02

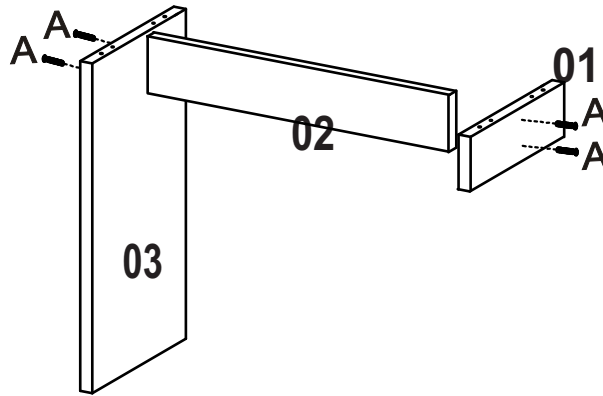
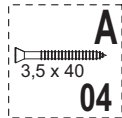

## Passo 03

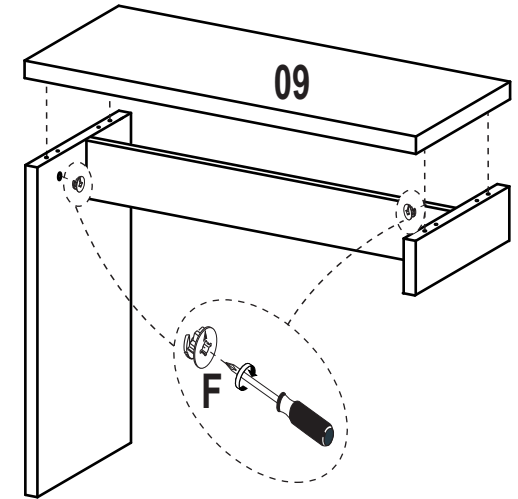
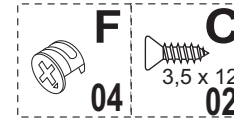

## Passo 04

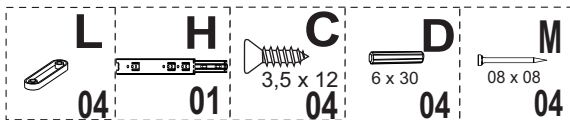

Separe as duas partes das correias telescópicas, seguindo os seguintes passos:

- 1 - Abra toda a correia;
- 2 - Empurre a trava de segurança para cima;
- 3 - Mantenha a trava levantada e puxe a ponta da correia para frente.

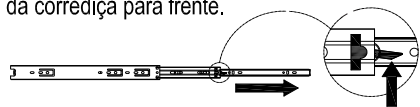

**PARTE 01**  
A PRIMEIRA PARTE FIXA NAS LATERAIS

**PARTE 02**  
A SEGUNDA PARTE FIXA NA LATERAL DE GAVETA

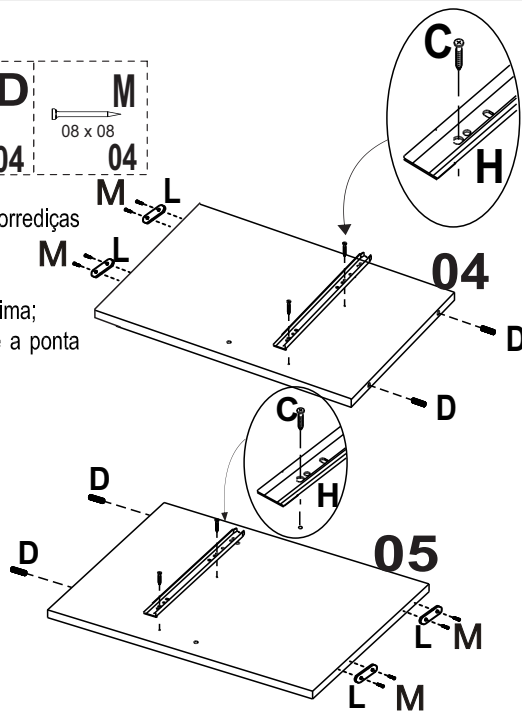

## Passo 05

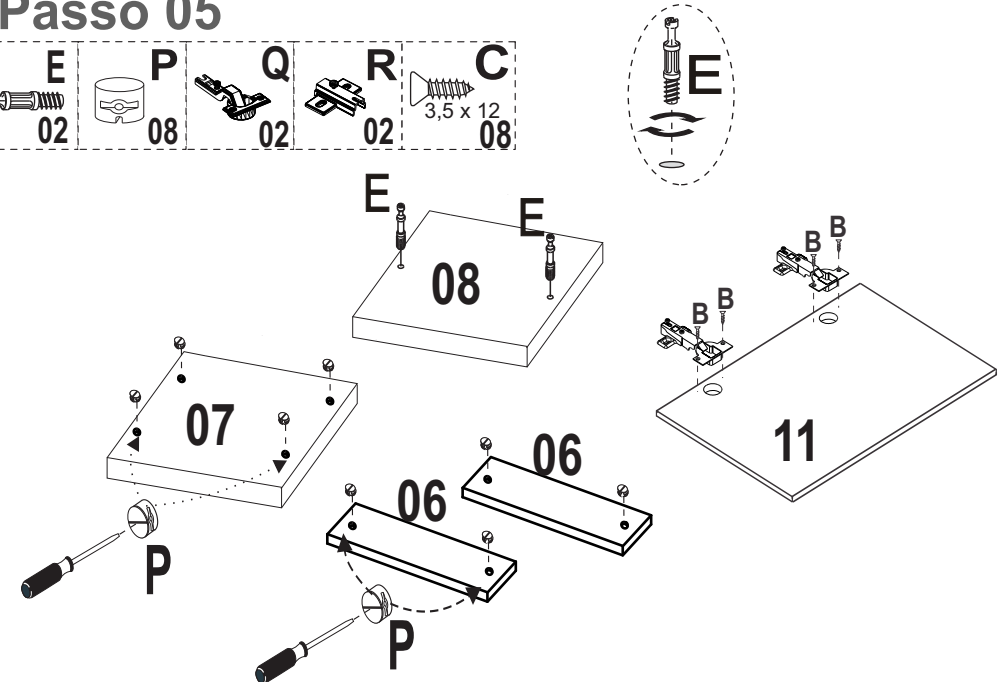

## Passo 06

### Amigo Montador

Com uma broca de 5mm você deverá  
Varar o furo do tampo do Gaveteiro  
para conseguir finalizar a montagem  
Lembrando sempre de escolher o  
Lado a ser montado primeiro

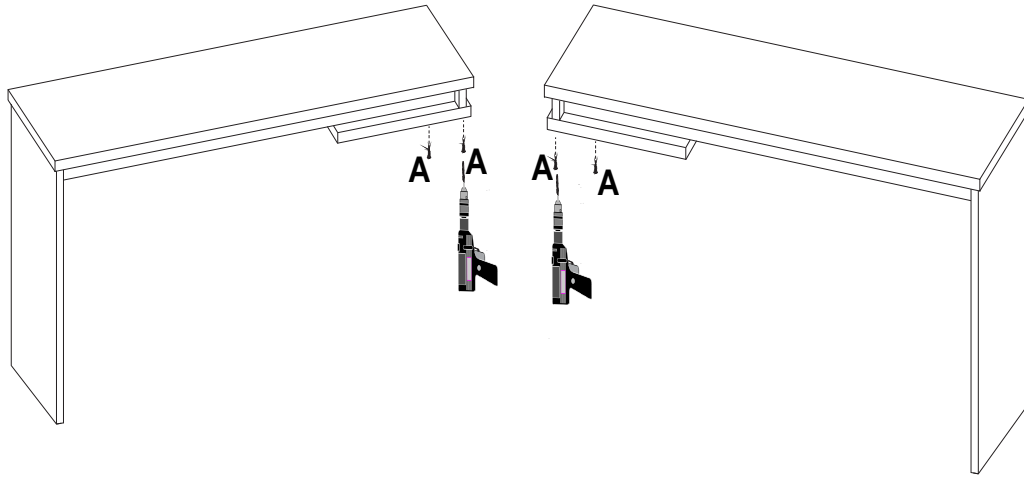
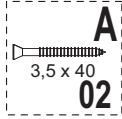

## Passo 06

### Amigo Montador

Com uma broca de 5mm você deverá  
Varar o furo do tampo do Gaveteiro  
para conseguir finalizar a montagem  
Lembrando sempre de escolher o  
Lado a ser montado primeiro

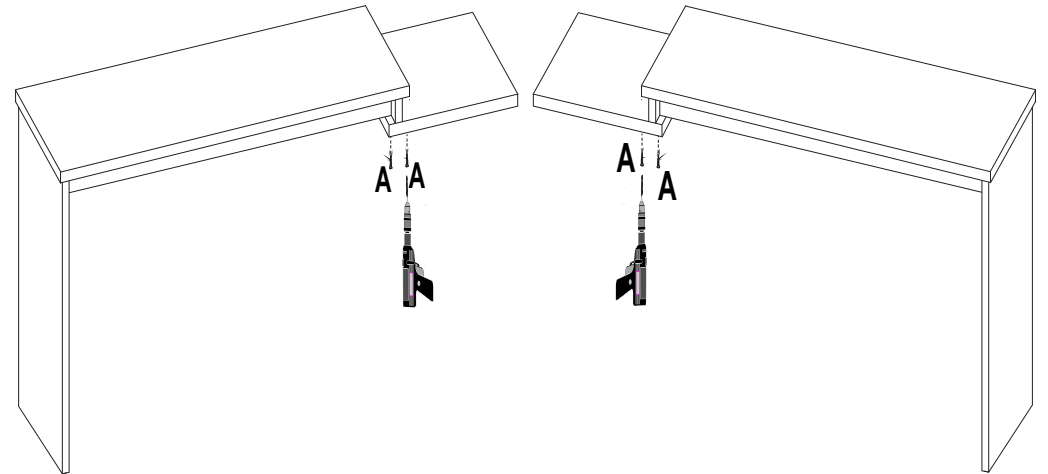
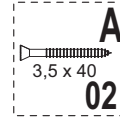

## Passo 07

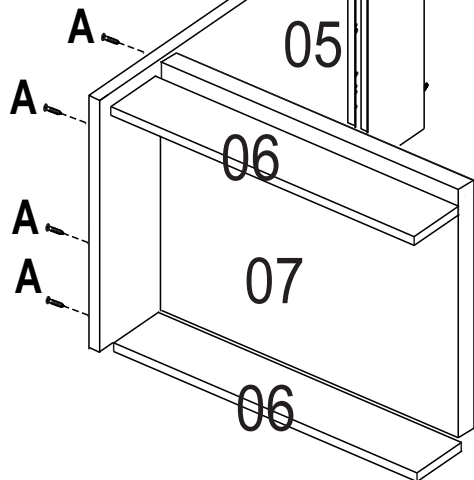
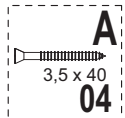

## Passo 08

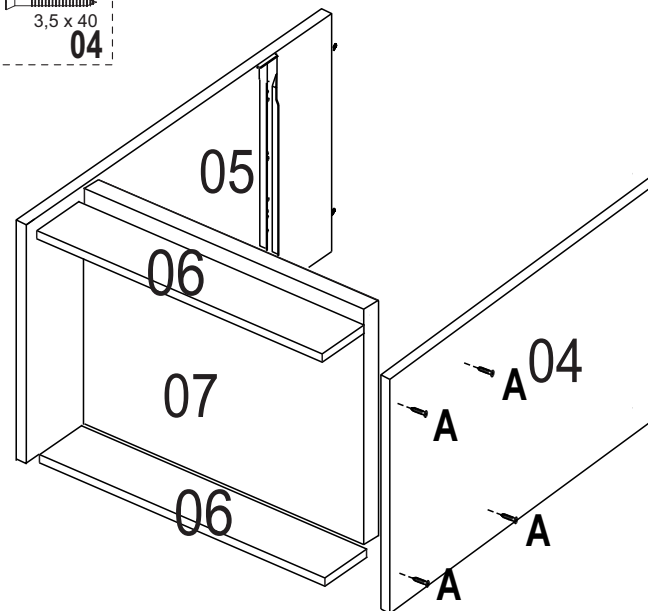
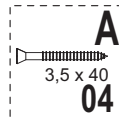

## Passo 09

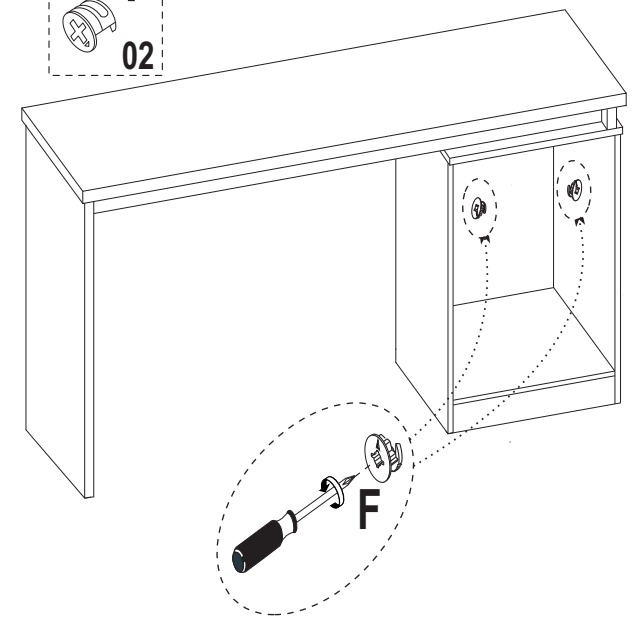

## Passo 10

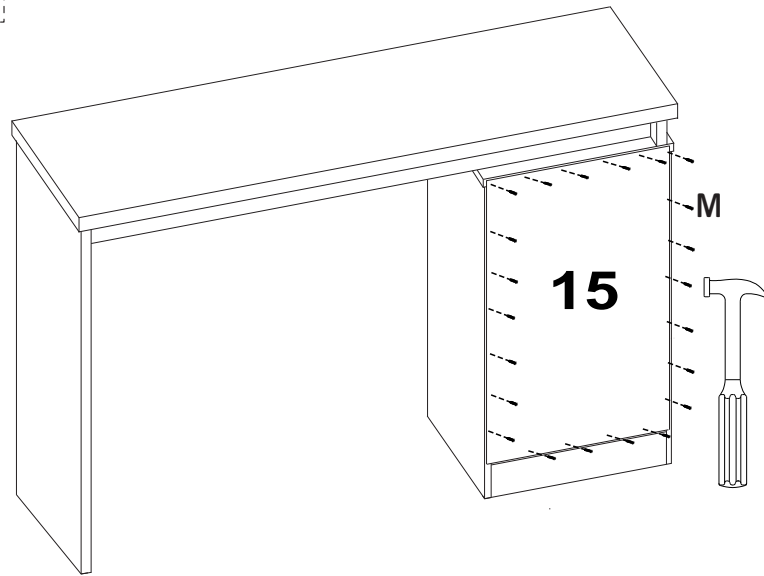
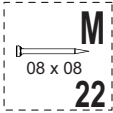

## Passo 11

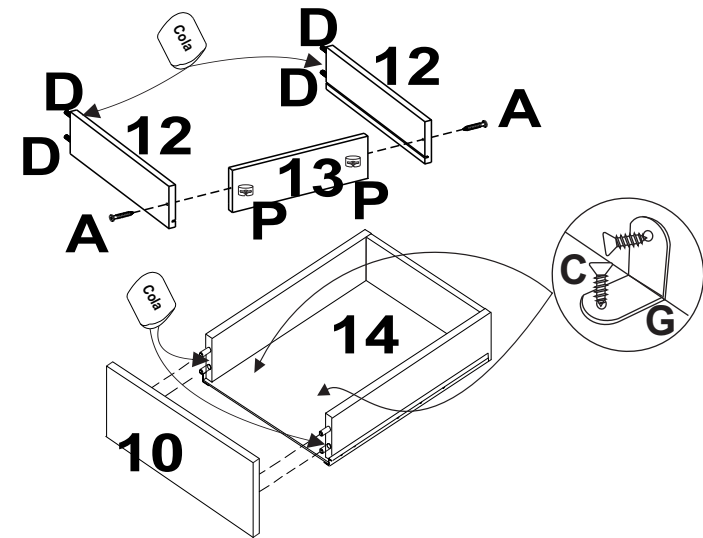
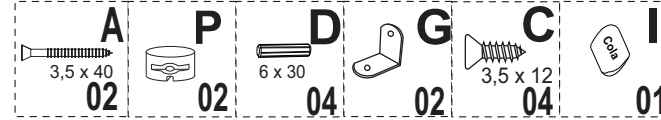

## Passo 12

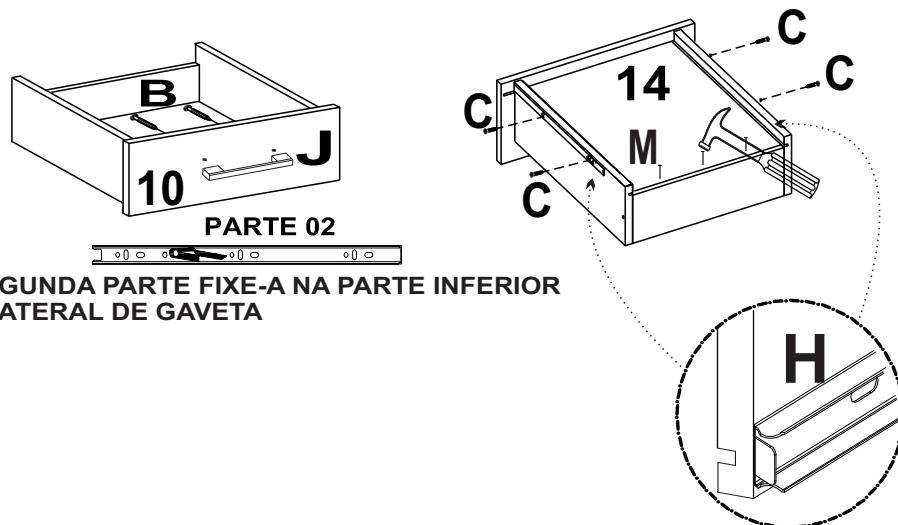
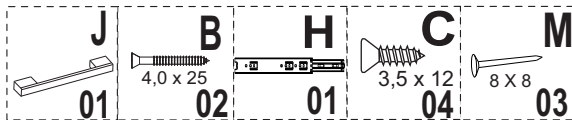

## Passo 13

